

## PRODUCT DESCRIPTION

The Emergency Eye/Facwash Mixing Valve shall control and maintain the temperature of the water to the station. Unit shall be self contained and include a thermostatic water mixing valve, a dial thermometer on the outlet, angle checkstops, wall mounting bracket, piping and fittings factory assembled and tested, top or bottom inlets and top outlet, unit set for 85°F (29°C) and a maximum temperature of 90°F (32°C). Unit must be able to be set to the correct temperature for the industry recommendations but must be locked in place to prevent changing of the temperature by accident. Unit must be checked weekly for performance in conjunction with the requirements of ANSI Z358.1. Unit shall be able to flow a minimum flow of 4 GPM (15 l/min) at 30 PSI (2.1 Bar).

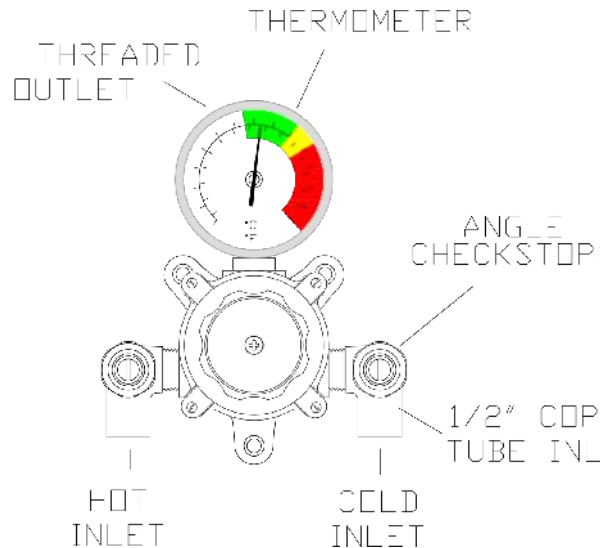

## INSTALLATION

1. Valve should be installed at a location where it can easily be cleaned, adjusted or repaired.
2. The inlets are clearly marked on the valve body casting. Connect the hot water into the inlet marked "HOT" and cold water into the inlet marked "COLD."
3. The checkstops furnished must be installed on both supply lines as shown above.
4. Use solder or pipe cement sparingly. Supply pipes should be flushed before the valve is connected. Flush outlet pipe and valve as soon as it is connected.

**Maximum Operating Pressure 125PSI (860 KPA) for Hot and Cold Water.**

**NOTE: It may be necessary to recirculate the tempered water to the face/eyewash should the piping be exposed to excessive hot or cold conditions. Consult factory for proper piping.**

## CAUTION

**IMPORTANT! These systems are designed to provide mixed water from 60 to 90°F (15 to 32°C) for eye/face wash applications only.**

**REMEMBER! THIS IS A CONTROL DEVICE WHICH MUST BE CLEANED AND MAINTAINED ON A REGULAR BASIS. (SEE MAINTENANCE GUIDE AND RECORD, MGR-1001).**

## ADJUSTMENT AND SERVICE

Encon Thermostatic Water Mixing Valves are simple in design and may be easily cleaned, adjusted and repaired. If the installation is accessible, servicing may be completed without disconnecting the valve.

**NOTE:** Thermostatic Water Mixing Valves are REGULATING mechanisms, which must be regularly maintained to provide best performance. Frequency of cleaning depends on quality of local water conditions and usage. (See Maintenance Guide and Record MGR-1000 and ANSI Z358.1).

### TO RESET ADJUSTABLE HIGH TEMPERATURE LIMIT STOP:

- 1.Remove handle, retaining ring and loosen set screw, and remove stop.
- 2.Turn emergency fixture on.
- 3.Replace handle on stem and turn stem until desired maximum temperature is reached.
- 4.Replace stop so it rests against the web on the LEFT side of the cover.
- 5.Set operating temperature, tighten set screw and resemble.

## WARNING

**WARNING!** This Thermostatic Mixing Valve has an adjustable high temperature limit stop which must be checked. If temperature is too high, the installer **MUST RESET** this stop immediately. Always check the temperature of the mixed water when the lever handle is turned to full **HOT**. Excessively hot water is **DANGEROUS AND MAY CAUSE SCALDING!**

The high temperature limit stop is factory set at approximately 90°F (32°C) with an incoming hot water supply temperature of 135°F (57°C). If the incoming hot water on the job is higher than 135°F, the valve when turned to full hot will deliver water in excess of 90°F (32°C) and the high temperature limit stop **MUST BE RESET BY THE INSTALLER.**

## TROUBLESHOOTING INSTRUCTIONS

<b>PACKINGS &amp; GASKETS</b>	Leak at pointer rod. Leak between valve cover and base.	<b>PARTS REQUIRED:</b> MU-5A O'Ring (2 req.) 6806 Cover Gasket
<b>PORT SLEEVE ASSEMBLY</b>	Valve outlet temperature cannot be adjusted or will not mix consistently.	TAG-1M Port Sleeve Assembly Or KIT# R/TA/M Rebuilding kit
<b>THERMOSTAT GROUP</b>	After cleaning or replacing port sleeve assembly, valve will not hold temperature.	6810 Thermostat Group Or KIT#R/TA/M Rebuilding kit
<b>CHECKSTOPS</b>	Hot water bypass in cold line. Supplies cannot be shut off completely. Leak at checkstop bonnet.	KIT# 4/LVC ECC-STV-300LF

### SEE PAGE 5 FOR COMPLETE PARTS BREAKDOWN AND PARTS KITS

If installed on a circulated hot water system, make certain the valve is piped according to Leonard Required Methods of Piping (see page 3).

**REMEMBER! THIS IS A CONTROL DEVICE WHICH MUST BE CLEANED AND MAINTAINED ON A REGULAR BASIS. (SEE MAINTENANCE GUIDE AND RECORD, MGR-1001).**

## REQUIRED METHOD OF PIPING ECC-STV-300-LF VALVE

Required when hot water is to be circulated to a thermostatic mixing valve which is a substantial distance from the hot water source.

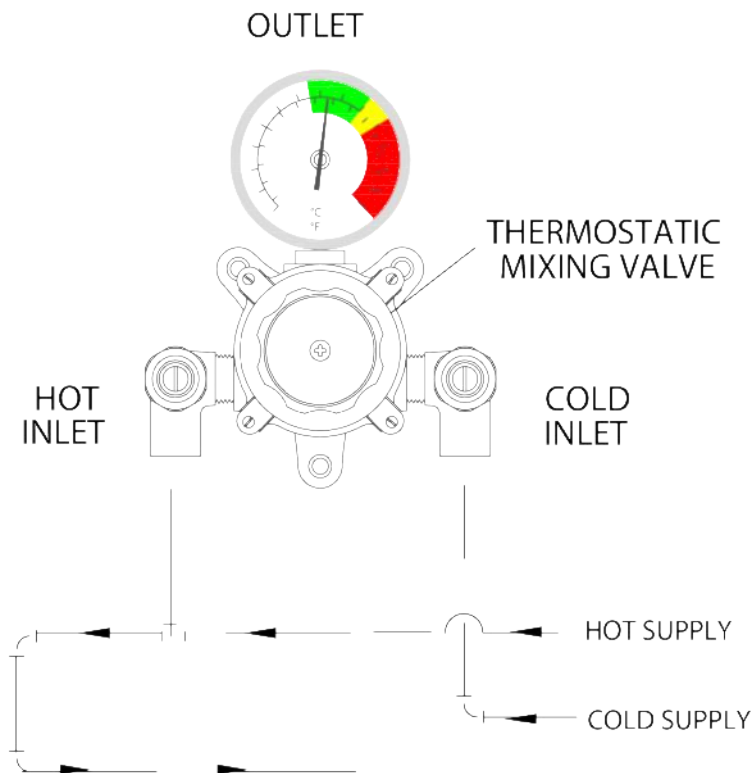

This unit must be cycled each time the emergency equipment is checked. See ANSI Z358.1, Maintenance and Training section.

Open eye/face wash and check to be sure outlet temperature does not climb above 90°F (32°C).

Turn primary thermostatic valve to full cold and wait ten seconds.

Turn primary thermostatic valve to full hot and wait ten seconds.

Check to be sure outlet temperature does not climb above 90°F (32°C).

Turn primary thermostatic mixing valve to full cold and wait ten seconds.

Set primary thermostatic mixing valve to the desired temperature, adjust limit stop (see page 2) and close eye/face wash.

### INSTRUCTIONS FOR DISMANTLING VALVE

Turn off hot and cold supplies to this valve. Remove four cover screws, lift off cover and thermostat group (DWG 1). After installing new parts, it will be necessary to reset Pointer to obtain correct temperature range from Cold to Hot. See page 2 instructions "TO RESET ADJUSTABLE HIGH TEMPERATURE LIMIT STOP."

### TO CLEAN PORT SLEEVE ASSEMBLY

To clean port sleeve assembly (DWG 2.): Remove base stud. Back off port sleeve nut as far as it will go into base. Slide port sleeve assembly toward port sleeve nut and lift out of valve base. Clean port sleeve with a soft cloth; **DO NOT** use abrasives such as emery cloth or sandpaper. After cleaning, wash parts in clean water and reassemble in valve base. When reassembling port sleeve assembly **BE SURE TO INSTALL WITH SHORT SLOT END IN BASE AND LONG SLOT END AT PORT SLEEVE NUT.** Locate one set of port slots facing directly toward front of the valve. Tighten port sleeve nut just enough to hold port sleeve in place, (do not cramp or distort port sleeve by exerting excessive pressure when tightening port sleeve nut).

### TO CLEAN THERMOSTAT GROUP

To clean thermostat group (DWG 1.), remove handle by loosening lock screw and pull off. Remove stop retaining ring and stop. Remove thermostat group by pushing rod through cover. **BE CAREFUL NOT TO PULL COILS OUT OF SHAPE.** If deposit has collected on thermostat coil, clean it off with a brush in cleaning solution and wash well before reassembly. Cleaning solution should be non-corrosive and grit free.

To reassemble: be sure, port sleeve assembly is in place and is working freely from side to side. Reinstall base stud, then place thermostat group on base stud and **BE SURE DRIVING BALL ON PORT SLEEVE ASSEMBLY TAG-1M IS INSERTED IN HOLE ON LOWER COIL BRACKET (DWG 3.)** Move thermostat back and forth to be sure all parts are free. Replace cover on valve base, install the four cover screws, and turn on hot and cold water supplies. See instructions below "To Reset High Temperature Limit Stop" to properly reset limit stop.

After installation, adjustment, and cleaning, always check the temperature of the valve when turned to full **HOT** per the warning on the front page, using a thermometer. Also check and if necessary adjust the temperature of the hot water source. **EXCESSIVELY HOT WATER (OVER 90°F) IS DANGEROUS AND MAY CAUSE SCALDING!!**

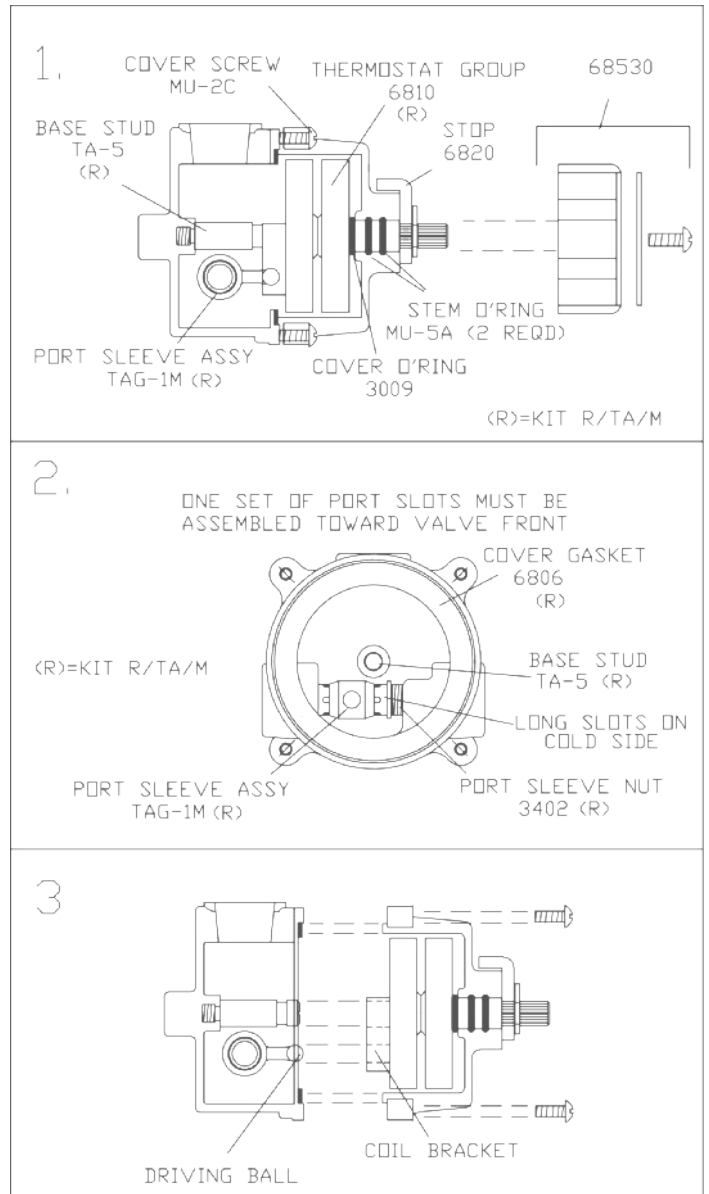

## ECC-STV-300-LF VALVE PARTS

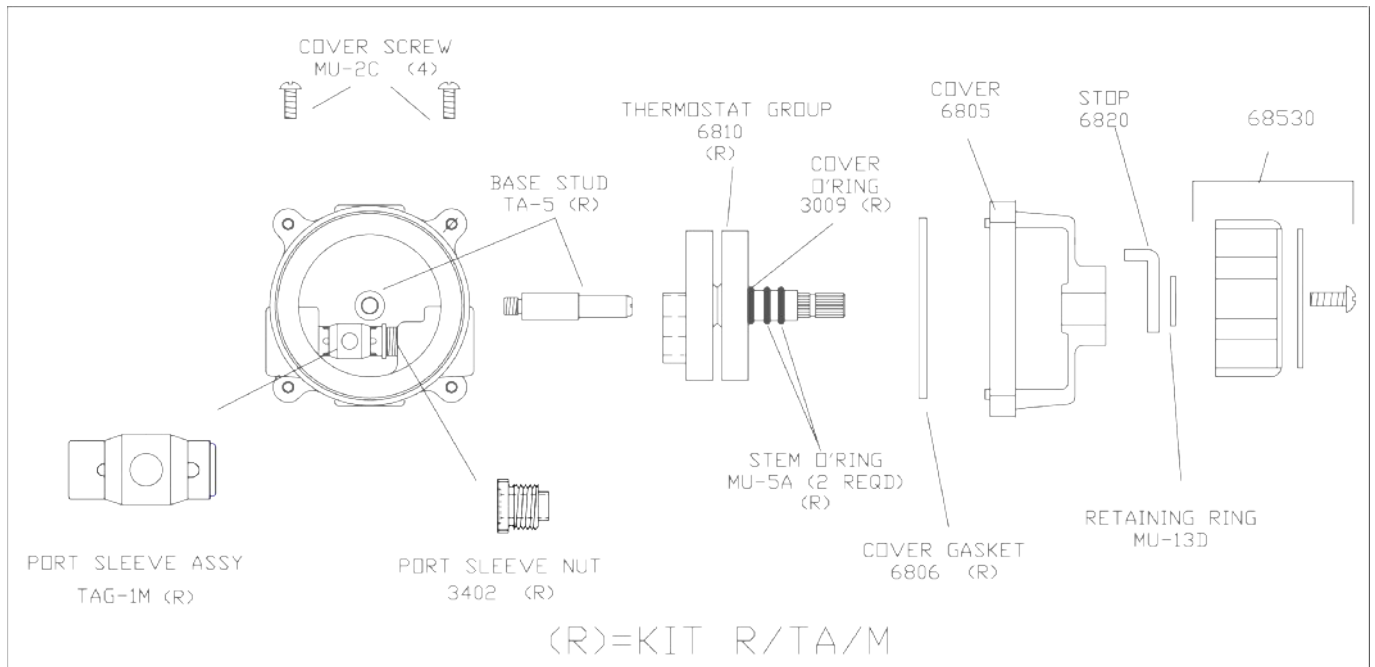

## CHECKSTOP PARTS

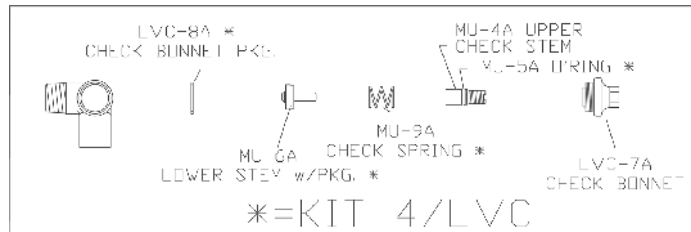

## REPAIR KIT

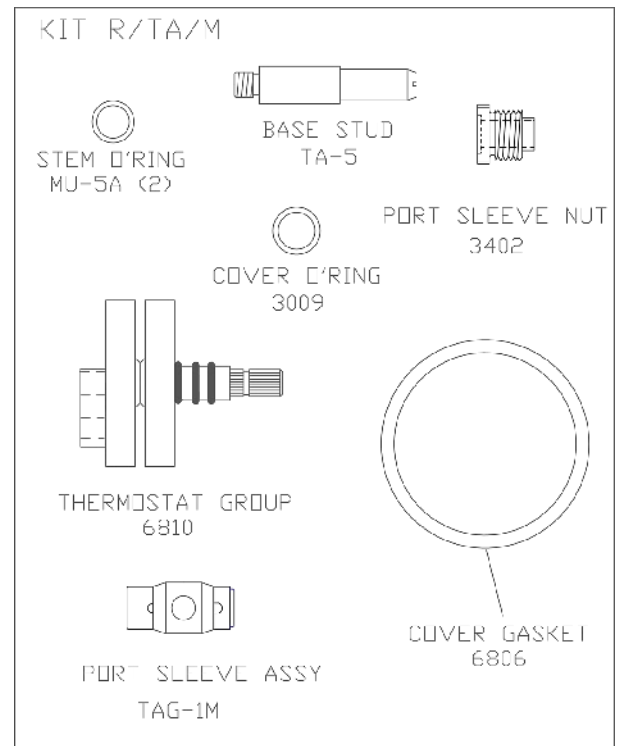

## LOCK-TYPE POINTER

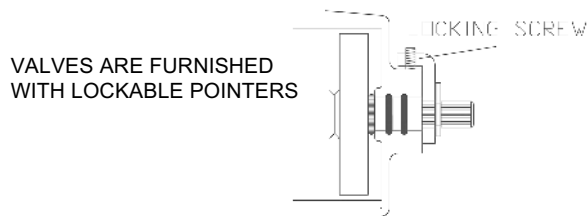

**NOTE: AFTER INSTALLING NEW PARTS IT WILL BE NECESSARY TO RESET THE ADJUSTABLE HIGH TEMPERATURE LIMIT STOP, (SEE PAGE 2).**

## FLOW CAPACITIES

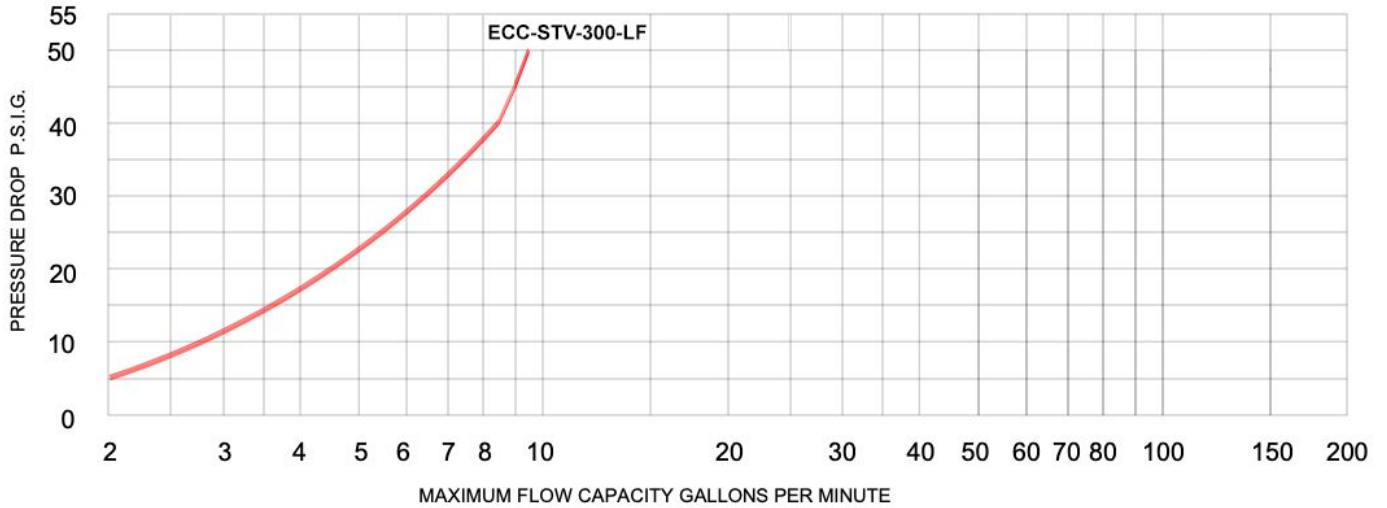

MODEL	IN	OUT	MINIMUM FLOW (GPM) L/MIN	INTERNAL COLD WATER BY-PASS MINIMUM	PRESSURE DROP									PSI BAR GPM L/MIN
					5 0.3	10 0.7	15 1.0	20 1.4	25 1.7	30 2.1	35 2.4	40 2.8	45 3.1	
ECC-STV-300LF	1/2"	1/2"	2.0	4	2.0	2.7	3.5	4.5	5.5	6.5	7.5	8.5	9.0	GPM
			7.6	15	7.6	10	13	17	21	25	28	32	34	L/MIN
MAXIMUM FLOW CAPACITY														

**CAUTION!** All thermostatic water mixing valves have limitations. They will not provide the desired accuracy outside of their flow capacity range. Consult the capacity chart and DO NOT OVERSIZE. Minimum flow must be no less than shown below.

**IMPORTANT!** These systems are designed to provide mixed water from 60 to 90°F (15 to 32°C) for face/eyewash applications only. Call Encon for systems designed to operate at temperatures outside of this range.

## WARRANTY STATEMENT

ENCON HEREBY DISCLAIMS ALL WARRANTIES EXPRESSED OR IMPLIED INCLUDING BUT NOT LIMITED TO WARRANTIES OF MERCHANTABILITY, FITNESS FOR A PARTICULAR PURPOSE, AND NON-INFRINGEMENT OF THIRD-PARTY RIGHTS, EXCEPT AS HEREINAFTER PROVIDED.

Encon Safety Products warrants that for one year from the date of purchase of any Encon products, the product will be free of defects in materials and workmanship if properly used and cared for or cleaned under normal conditions in accordance with Encon's use and care instructions and properly installed, if applicable, in accordance with Encon's installation instructions. With respect to the product, Encon's only obligation and purchaser's exclusive remedy under this warranty is to repair or replace such product; provided that:

1. Encon is notified of the defect within one year of shipment, and
2. the product is determined by Encon to be defective.

Encon requires proof of original ownership as proof of warranty coverage, and Encon must receive any claim under this Limited Warranty within one year of purchase of the product.

NOTWITHSTANDING ANYTHING TO THE CONTRARY CONTAINED HEREIN, ENCON SHALL NOT BE LIABLE FOR LOSS, DAMAGE, OR EXPENSE ARISING DIRECTLY OR INDIRECTLY AS A CONSEQUENCE OF USE OF THE EQUIPMENT WITH OTHER PRODUCTS OR FROM ANY OTHER CAUSE, INCLUDING ANY CONSEQUENTIAL, INCIDENTAL, SPECIAL OR EXEMPLARY DAMAGES, EXCEPT FOR ENCON'S OBLIGATION TO REPAIR OR REPLACE DEFECTIVE PRODUCTS AS EXPRESSLY PROVIDED IN THIS STATEMENT.

Replacement parts purchased from Encon are warranted for one year following the shipment of such replacement part, or until the expiration of the warranty period for the product, whichever is less. No warranty is given in connection with products that are altered without Encon's expressed written consent. The same warranty limitations and the obligations of Encon as set out herein above shall apply to replacement parts.

Encon's total liability arising out of this warranty (including, but not limited to, warranty claims) regardless of forum and regardless of whether such action or claim is based on tort, contract or otherwise will not exceed the total purchase price of the product.



6825 W. Sam Houston Pkwy. N (77041)  
P.O. Box 3826 • Houston, Texas (77253)  
(713) 466-1449  
1-800-AT-ENCON / 1-800-283-6266  
[customerservice@enconsafety.com](mailto:customerservice@enconsafety.com)  
<http://www.enconsafety.com>