



SELF-CONTAINED GRAVITY FED PORTABLE EYEWASH STATIONS



- MODEL 01104050 GRAVITY FED EYEWASH UNIT
- MODEL 01104055 GRAVITY FED EYEWASH STATION
- MODEL 01110700 TRANSPORT CART & RECEPTACLE
- MODEL 01110302 TRANSPORT CART ONLY

COMPONENT LIST FOR GRAVITY FED

(Ref. Figure 1 below)

- A: Gravity Fed Eyewash
- B: "J" Hook (1)
- C: Hydrosep® Water Preservative (not shown)

PRODUCT DESCRIPTION

Portable 14 Gallon Self-Contained Gravity Fed Eyewash units for use in areas where plumbed potable water is not available. Units are designed for wall mounting or mounting on a transport cart, as well as a stand-alone unit on a shelf.

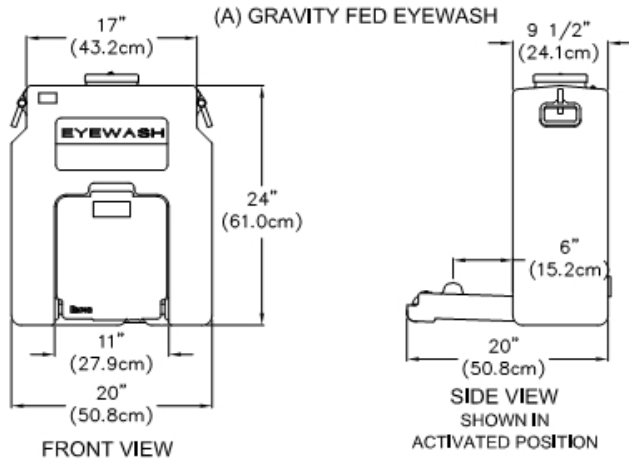

FIGURE 2
MODEL 01104050 SHOWN
(See installation instructions on page 4)

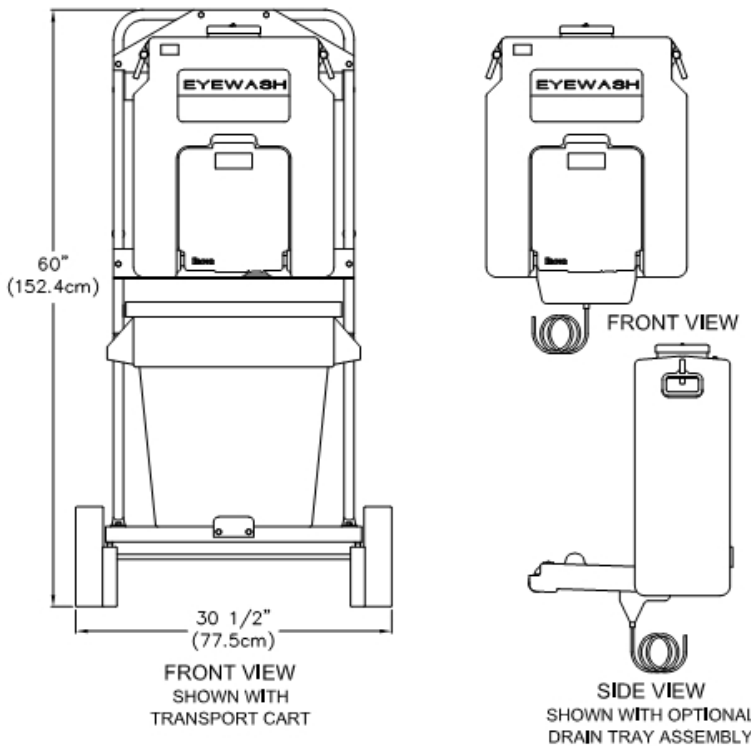

FIGURE 1



FIGURE 3
MODEL 01104055 SHOWN



NOTE: For Gravity Fed Eyewash Model 01104050 & 01104055, Plate (3) of cart assembly needs to be flipped 180° as indicated by large arrow below.

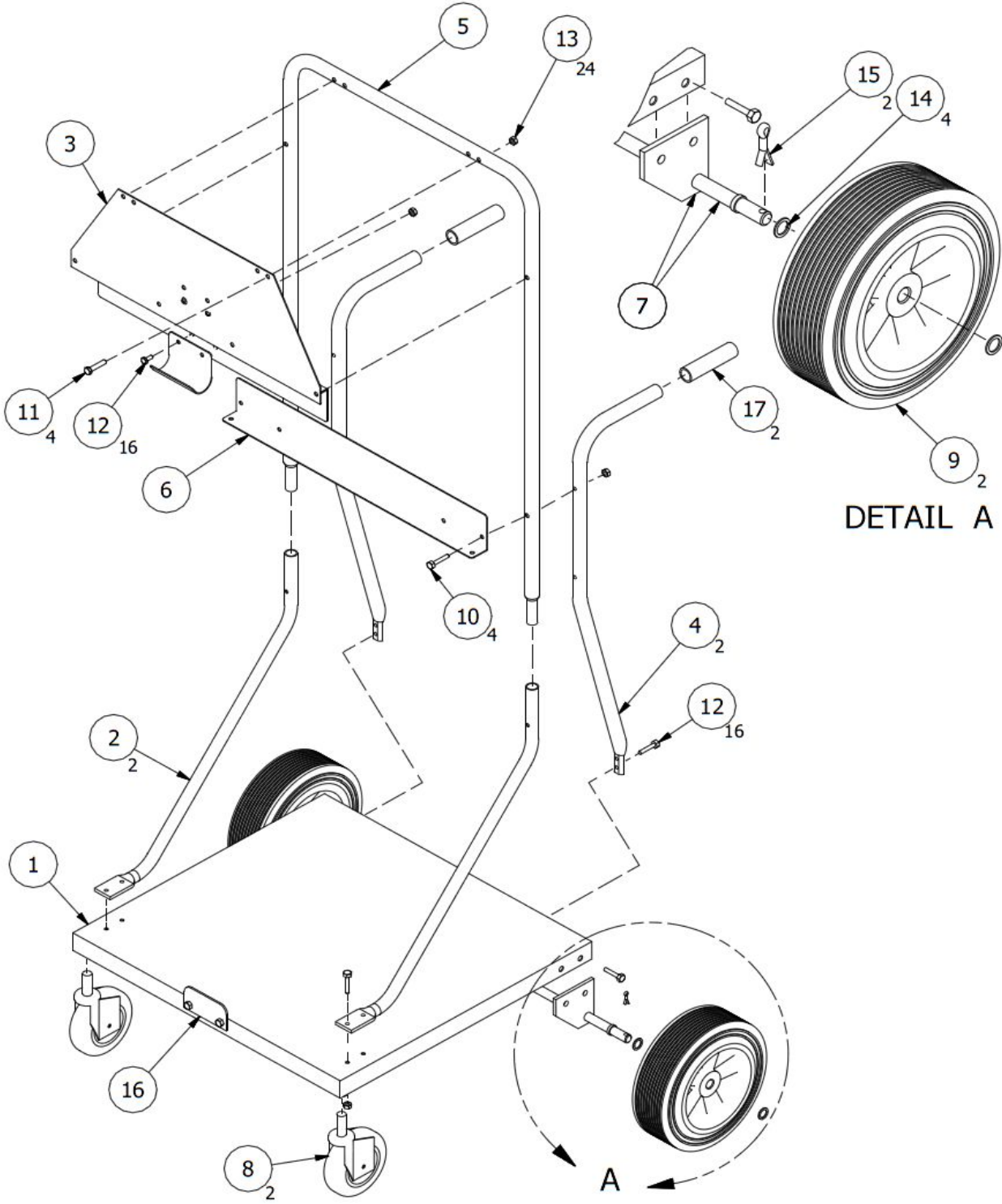

FIGURE 4

COMPONENT LIST FOR TRANSPORT CART MODEL 01110700 & MODEL 01110302

(Ref. Figure 4 on page 2)

1. Base Plate (1)
 2. Front Leg (2)
 3. Upper Support (1)
 4. Rear Leg (2)
 5. Upper Frame (1)
 6. Lower Support (1)
 7. Axle Assembly (1)
 8. Locking Caster (2)
 9. 10" Wheel (2)
 10. Bolt, 1/4-20x2-1/2" lg. (4)
 11. Bolt, 1/4-20x1-1/2" lg. (4)
 12. Bolt, 1/4-20x3/4" lg. (16)
 13. Lock Nut 1/4-20 (24)
 14. Flat Washer 5/8" (4)
 15. Cotter Pin (2)
 16. Stop Plate (1)
 17. Hand Grip (2)
- Receptacle (shown below)

TOOLS REQUIRED

- Hammer
- Pliers
- 7/16" Wrenches (2)

INSTALLATION INSTRUCTIONS FOR TRANSPORT CART

(Ref. Figure 4 on page 2)

1. Attach axle assembly (#7) to base plate (#1) using four 3/4" long bolts (#12) and lock nuts (#13).
2. Place 5/8" washer (#14), then 10" wheel (#9), 5/8" washer (#14), and cotter pin (#15) on each end of axle (#7). Collar on wheel hub should be installed facing the base plate (#1) on cart.
3. Tap casters (#8) into sockets on base plate (#1) front, be careful not to damage wheels.
4. Push hand grips (#17) onto rear legs (#4).
5. Attach upper support (#3) to upper frame (#5) using four 1 1/2" long bolts (#11) and lock nuts (#13). Frame should be assembled with bolts hand tight, then tightened all bolts with wrench when assembly is complete.
6. Insert front legs (#2) onto upper frame (#5).
7. Attach lower support (#6) to upper frame (#5) and to rear legs (#4) using two 2 1/2" long bolts (#10) and lock nuts (#13).
8. Attach front legs (#2) to rear legs (#4) using two 2 1/2" long bolts (#10) and lock nuts (#13).
9. Connect support assembly to base plate (#1) using eight 3/4" long bolts (#12) and lock nuts (#13).
10. Install stop plate (#16) to base plate (#1) using two 3/4" long bolts (#12) and lock nuts (#13).
11. Install eyewash "J" hook (supplied with Encon Gravity Fed Eyewash) to upper support (#3) using two 3/4" long bolts (#12) and lock nuts (#13). Use lowest mounting holes for Encon Gravity Fed Eyewash, middle holes for Haws or Speakman, upper holes for Fendall.
12. Place Gravity Fed Eyewash and receptacle on cart as shown in Figure 5 below. Installation instructions for Gravity Fed Eyewash unit is on page 4.
13. Test for proper operation.
14. Place station in desired location. Lock front wheels by depressing silver tab on wheels.

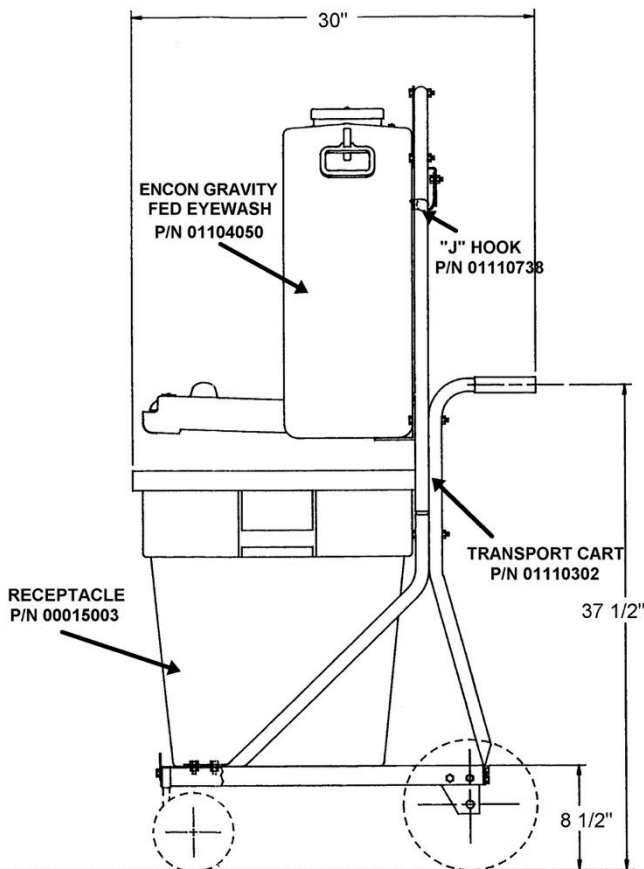

**FIGURE 5 - SIDE VIEW
GRAVITY FED EYEWASH STATION
MODEL 01104055**

INSTALLATION INSTRUCTIONS FOR GRAVITY FED EYEWASH

**CAUTION: Adequate shelf or wall support is recommended.
Unit weighs in excess of 120 lbs. when filled to capacity.**

1. Inspect and rinse tank, if necessary.
2. The unit may be mounted on a wall, on Encon transport cart, or as a stand-alone unit on a shelf. In both cases, the eyewash heads should be 33" to 45" from the floor when in open position.
3. When mounting on a shelf, tray should be able to fully open without any obstacles.
4. When wall mounting, install "J" hook to proper support beam 49-61 inches from the floor to the top of the "J" hook, using proper mounting screws (mounting screws are not included). See Figure 1 on page 1 for reference.
5. When mounting on Encon transport cart, see Installation Instructions for Transport Cart on page 3.
6. Fill tank with potable water up to the appropriate fill-line and add Hydrosep® water preservative. Follow directions on Hydrosep® container.
7. Pull down eyewash tray to activate and test unit for proper flow pattern.

OPERATION AND MAINTENANCE

1. Keep tray closed to protect eyewash heads and shut off flow. Do not lean on tray when in open position.
2. Clean tank with mild soap and water as needed. Rinse well and refill with potable water to appropriate fill-line and add Hydrosep® water preservative.
3. Unit should be drained, flushed, and refilled with clean potable water and Hydrosep® water preservative. Encon recommends cleaning and replacing the fluid every 90 to 120 days (not to exceed 180 days). Follow the directions printed on the Hydrosep® bottle.
4. Unit should be activated for 15 seconds to flush lines and inspected annually to verify proper operation. Refill to appropriate fill-line after each test and add Hydrosep® water preservative if six gallons (cumulative) or more is used during the testing procedures. Inspection should include examination of hose connecting reservoir and basin, and reservoir should be free of fungi, algae or other foreign materials.
5. Test records should be maintained verifying compliance with testing procedures.

GENERAL INFORMATION

Following are requirements of ANSI Z358.1 for Emergency Eyewash and Shower Equipment. A complete copy of this standard may be purchased from International Safety Equipment Association.

1. Eyewash units shall be in accessible locations that require no more than 10 seconds travel time from the farthest hazard.
2. Employees shall be instructed in the proper use of emergency eyewash equipment.
3. Each unit location shall be identified with a highly visible sign. The area around the unit shall be well lit.
4. Units shall be inspected annually for proper operation to ensure compliance to ANSI Z358.1 standard.

TRAINING

All employees who might be exposed to hazardous material shall be instructed in the location and proper use of emergency shower and eye/facewash units. Experiences have shown that initial first-aid treatment for irritants should be to wash the eyes and face for 15 minutes prior to medical treatment. It is important to hold the eyelids open and roll the eyes so water will flow on all surfaces and in the folds surrounding the eyes.

SPARE PARTS LIST

P/N 01110764	Hydrosep® Water Preservative (4 pack 8 oz. bottles)
P/N 01110792	Replacement Discharge Hose Kit P/N 01110700
P/N 01110720	Male Latch
P/N 01110721	Female Latch
P/N 01110738	"J" Hook

ACCESSORIES

P/N 01110729	Drain Tray Kit
P/N 01110700	Transport Cart & Receptacle
P/N 00015003	Receptacle
P/N 01110302	Transport Cart

WARRANTY STATEMENT

ENCON HEREBY DISCLAIMS ALL WARRANTIES EXPRESSED OR IMPLIED INCLUDING BUT NOT LIMITED TO WARRANTIES OF MERCHANTABILITY, FITNESS FOR A PARTICULAR PURPOSE, AND NON-INFRINGEMENT OF THIRD-PARTY RIGHTS, EXCEPT AS HEREINAFTER PROVIDED.

Encon Safety Products warrants that for one year from the date of purchase of any Encon products, the product will be free of defects in materials and workmanship if properly used and cared for or cleaned under normal conditions in accordance with Encon's use and care instructions and properly installed, if applicable, in accordance with Encon's installation instructions. With respect to the product, Encon's only obligation and purchaser's exclusive remedy under this warranty is to repair or replace such product; provided that:

1. Encon is notified of the defect within one year of shipment, and
2. the product is determined by Encon to be defective.

Encon requires proof of original ownership as proof of warranty coverage, and Encon must receive any claim under this Limited Warranty within one year of purchase of the product.

NOTWITHSTANDING ANYTHING TO THE CONTRARY CONTAINED HEREIN, ENCON SHALL NOT BE LIABLE FOR LOSS, DAMAGE, OR EXPENSE ARISING DIRECTLY OR INDIRECTLY AS A CONSEQUENCE OF USE OF THE EQUIPMENT WITH OTHER PRODUCTS OR FROM ANY OTHER CAUSE, INCLUDING ANY CONSEQUENTIAL, INCIDENTAL, SPECIAL OR EXEMPLARY DAMAGES, EXCEPT FOR ENCON'S OBLIGATION TO REPAIR OR REPLACE DEFECTIVE PRODUCTS AS EXPRESSLY PROVIDED IN THIS STATEMENT.

Replacement parts purchased from Encon are warranted for one year following the shipment of such replacement part, or until the expiration of the warranty period for the product, whichever is less. No warranty is given in connection with products that are altered without Encon's expressed written consent. The same warranty limitations and the obligations of Encon as set out herein above shall apply to replacement parts.

Encon's total liability arising out of this warranty (including, but not limited to, warranty claims) regardless of forum and regardless of whether such action or claim is based on tort, contract or otherwise will not exceed the total purchase price of the product.



6825 W. Sam Houston Pkwy. N (77041)
P.O. Box 3826 • Houston, Texas (77253)
(713) 466-1449 • Fax (713) 466-1819
1-800-AT-ENCON / 1-800-283-6266
E-Mail: customerservice@enconsafety.com
Website: www.enconsafety.com